

TaiShan 200 Server

White Paper (Model 5280)

Issue 05
Date 2020-06-22



HUAWEI TECHNOLOGIES CO., LTD.

Copyright © Huawei Technologies Co., Ltd. 2020. All rights reserved.

No part of this document may be reproduced or transmitted in any form or by any means without prior written consent of Huawei Technologies Co., Ltd.

Trademarks and Permissions



HUAWEI and other Huawei trademarks are trademarks of Huawei Technologies Co., Ltd.

All other trademarks and trade names mentioned in this document are the property of their respective holders.

Notice

The purchased products, services and features are stipulated by the contract made between Huawei and the customer. All or part of the products, services and features described in this document may not be within the purchase scope or the usage scope. Unless otherwise specified in the contract, all statements, information, and recommendations in this document are provided "AS IS" without warranties, guarantees or representations of any kind, either express or implied.

The information in this document is subject to change without notice. Every effort has been made in the preparation of this document to ensure accuracy of the contents, but all statements, information, and recommendations in this document do not constitute a warranty of any kind, express or implied.

Huawei Technologies Co., Ltd.

Address: Huawei Industrial Base
Bantian, Longgang
Shenzhen 518129
People's Republic of China

Website: <https://www.huawei.com>

Email: support@huawei.com

Contents

1 Overview	1
2 Features	2
3 Logical Structure	4
4 Hardware Description	8
4.1 Appearance	8
4.2 Indicators and Buttons	12
4.3 Riser Cards and PCIe Slots	18
4.4 Physical Structure	25
5 Product Specifications	28
5.1 Technical Specifications	28
5.2 Environmental Specifications	31
5.3 Physical Specifications	33
6 Software and Hardware Compatibility	34
6.1 CPU	34
6.2 Memory	35
6.3 Storage	41
6.4 I/O Expansion	43
6.5 PSU	43
7 System Management	45
8 Maintenance and Warranty	47
9 Certifications	48

1 Overview

The TaiShan 200 server powered by Huawei Kunpeng 920 processors is dedicated for data centers. Its 5280 storage model (5280 for short) is a 4U 2-socket rack server. It features high-performance computing, large-capacity storage, low power consumption, easy management, and easy deployment and is ideal for storage services.

Figure 1-1 Appearance



2 Features

Performance and Scalability

The 5280 provides the following features to enhance performance and scalability:

- The server uses Huawei server-oriented 64-bit high-performance multicore Kunpeng 920 7260, 5250, 5240, 5230, 5220, or 3210 processor. Each processor integrates DDR4, PCIe 4.0, 25GE, 10GE, and GE ports and provides the system-on-chip (SOC) function. Each processor provides the following features:
- Each server supports up to two processors and 128 cores, maximizing the concurrent execution of multithreaded applications.
- Each Kunpeng 920 7260, 5250, 5240, or 5230 processor supports up to thirty-two 2933 MHz DDR4 ECC RDIMMs, which provide a maximum of 4096 GB memory capacity. Each Kunpeng 920 5220 or 3210 processor supports up to sixteen 2933 MHz DDR4 memory modules, which provide a maximum of 2048 GB memory capacity.

NOTE

The memory speed is 2933 MHz for a 1-DPC memory module, and 2666 MHz for a 2-DPC memory module.

- Flexible drive configurations cater to a variety of business requirements and ensure high elasticity and scalability of storage resources.
- FlexIO cards provide multiple Ethernet ports.
- A maximum of eight PCIe 4.0 x8 slots are provided for easy expansion.

Availability and Serviceability

The 5280 provides the following features to improve availability and serviceability:

- The 5280 uses carrier-class components and follows the engineering process to dramatically improve system reliability.
- The 5280 is equipped with SAS/SATA/NVMe drives. SAS/SATA drives support RAID 0, 1, 10, 5, 50, 6, and 60, provides RAID cache, uses a supercapacitor for power-off data protection, and allows hot swap of data drives.
- The UID and HLY indicators on the panel and iBMC WebUI help technical support personnel promptly obtain the status of key components and locate failed or failing components. This simplifies maintenance, accelerates troubleshooting, and improves system availability.

- The Huawei intelligent baseboard management controller (iBMC) monitors system parameters in real time, triggers alarms, and performs recovery actions in case of failures. This helps minimize system downtime.

Manageability and Security

The 5280 provides the following features to ensure manageability and security:

- The iBMC monitors server operating status and provides remote management.
- The integrated industry-standard Unified Extensible Firmware Interface (UEFI) increases efficiency of setup, configuration, and update, and simplifies fault handling.
- The front bezel in the server chassis is locked to ensure local data security and reliability.

Energy Efficiency

The 5280 provides the following features to improve energy efficiency:

- The 5280 supports Platinum power supply units (PSUs), which provide 94% power efficiency at 50% load.
- The voltage regulator-down (VRD) PSUs reduce the energy loss in DC/DC power conversion.
- The server supports active/standby power supplies.
- The 5280 supports Proportional-Integral-Derivative (PID) intelligent fan speed adjustment, reducing power consumption.
- The improved thermal design with energy-efficient fan modules ensures optimal heat dissipation and reduces overall system power consumption.
- Drives can be powered on at different times to reduce startup power consumption.
- The 5280 supports SSDs. SSDs consume 80% less power than HDDs.

3 Logical Structure

Figure 3-1 shows the logical structure of the 5280 equipped with Kunpeng 920 7260, 5250, 5240, or 5230 processors.

Figure 3-1 Logical structure of the server with Kunpeng 920 7260, 5250, 5240, or 5230 processors

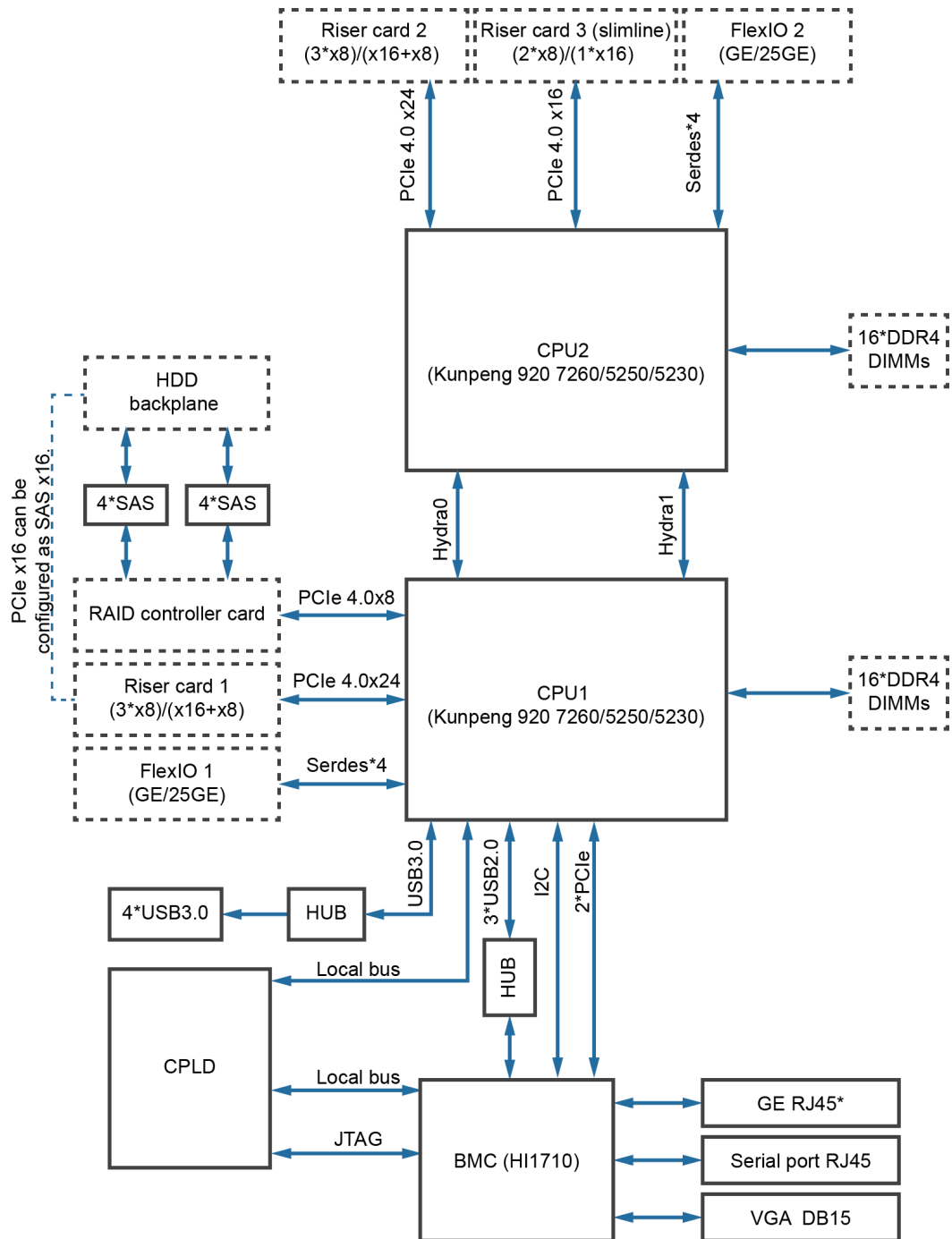

- The 5280 supports two Huawei Kunpeng 920 7260, 5250, 5240, or 5230 processors (CPUs). Each processor supports 16 DDR4 DIMMs.
- The server can come with an Ethernet FlexIO card with four GE or 25GE ports, which are connected to the processors through the high-speed SerDes interface.
- The screw-in RAID controller card connects to CPU 1 through PCIe buses, and to the drive backplanes through SAS signal cables. The server supports flexible drive configurations, depending on the drive backplanes used.

- The intelligent baseboard management controller (iBMC) uses the Huawei Hi1710 and provides a VGA port, management network port, and debugging serial port.

Figure 3-2 shows the logical structure of the 5280 equipped with Kunpeng 920 5220 or 3210 processors.

Figure 3-2 Logical structure of the server with Kunpeng 920 5220 or 3210 processors

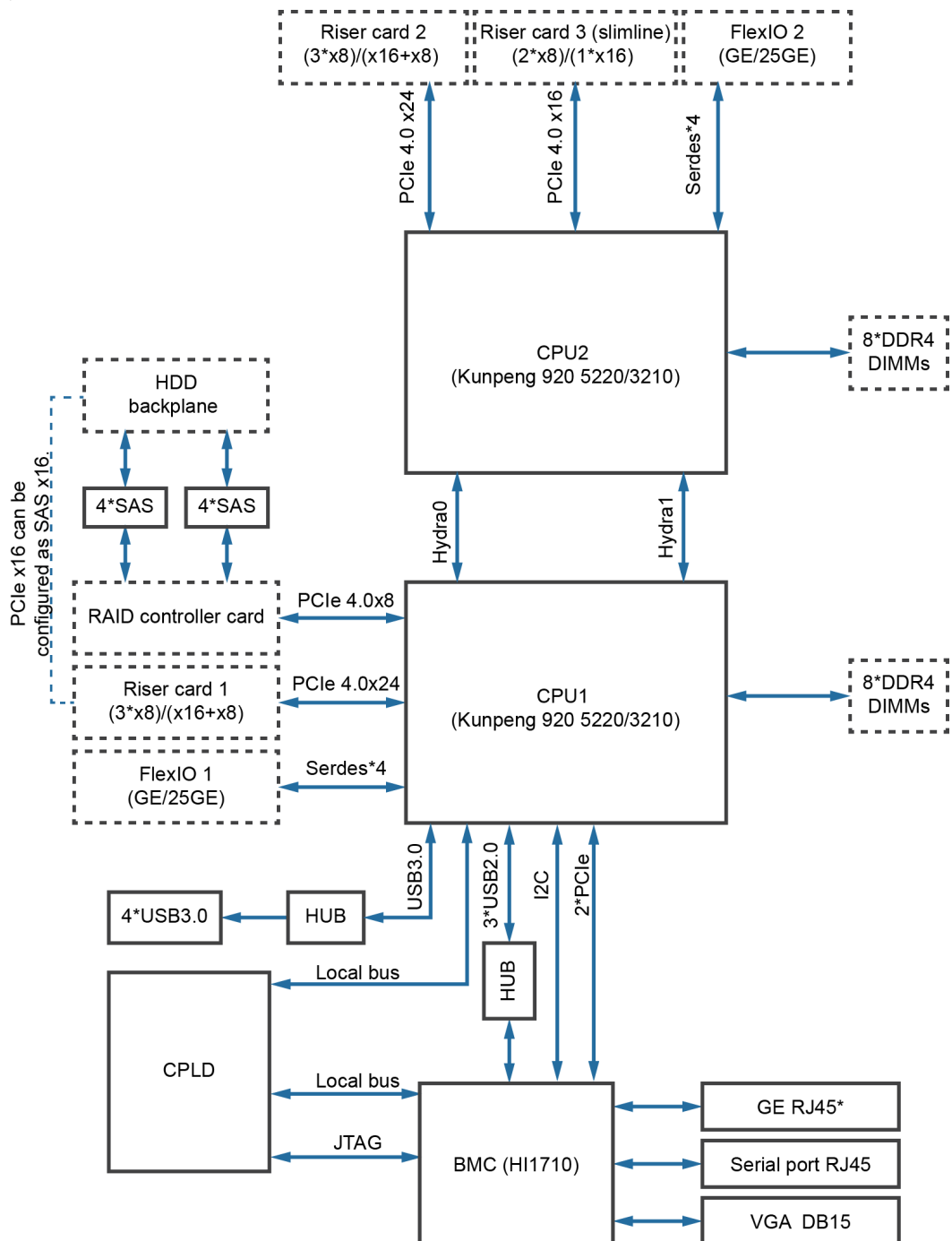

- The 5280 supports two Huawei Kunpeng 920 5220 or 3210 processors (CPUs). Each processor supports 8 DDR4 DIMMs.

- The server can come with an Ethernet FlexIO card with four GE or 25GE ports, which are connected to the processors through the high-speed SerDes interface.
- The screw-in RAID controller card connects to CPU 1 through PCIe buses, and to the drive backplanes through SAS signal cables. The server supports flexible drive configurations, depending on the drive backplanes used.
- The iBMC uses the Huawei Hi1710 and provides a VGA port, management network port, and debugging serial port.

4 Hardware Description

- 4.1 Appearance
- 4.2 Indicators and Buttons
- 4.3 Riser Cards and PCIe Slots
- 4.4 Physical Structure

4.1 Appearance

Front Panel

Figure 4-1 shows the components on the front panel of the server.

Figure 4-1 Components on the front panel of the server



1	Drive	2	VGA port
3	USB 3.0 port	4	Label plate with an SN label

Table 4-1 Description of ports on the front panel

Port	Type	Description
USB port	USB 3.0	The USB ports allow USB devices to be connected to the server. NOTE Before connecting an external USB device, check that the USB device functions properly. A server may operate abnormally if an abnormal USB device is connected.
VGA port	DB15	The VGA port is connected to a terminal, such as a monitor or physical KVM. NOTE The VGA port on the front panel does not have cable screws. The VGA cable is easy to fall off. You are advised to use the VGA port on the rear panel.

SN

The serial number (SN) on the label is a string that uniquely identifies a server. The SN is required when you contact Huawei technical support.

Figure 4-2 shows the SN format.

Figure 4-2 SN example



Table 4-2 SN description

No.	Description
1	SN ID (two characters), which is 21 .
2	Material identification code (eight characters), that is, processing code.
3	Code of a processing factory (two characters). The value 10 indicates Huawei.

No.	Description
4	Year and month (two characters). <ul style="list-style-type: none"> The first character indicates the year. Digits 1 to 9 indicate 2001 to 2009, letters A to H indicate 2010 to 2017, letters J to N indicate 2018 to 2022, and letters P to Y indicate 2023 to 2032. NOTE The years from 2010 are represented by upper-case letters excluding I, O, and Z because the three letters are similar to digits 1, 0, and 2. <ul style="list-style-type: none"> The second character indicates the month. Digits 1 to 9 indicate January to September, and letters A to C indicate October to December.
5	Serial number (six characters).
6	RoHS compliance (one character). Y indicates environment-friendly processing.
7	Board model, that is, product name.

Rear Panel

Figure 4-3 shows the components on the rear panel of the server.

Figure 4-3 Rear Panel Components

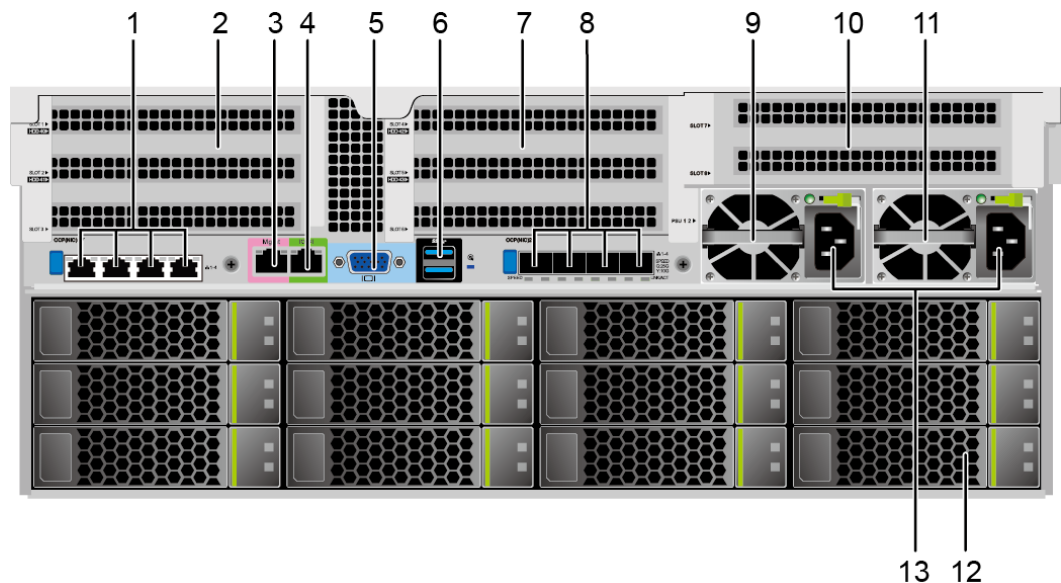

1	FlexIO 1	2	I/O module 1
3	Management network port	4	Serial port
5	VGA port	6	USB 3.0 port
7	I/O module 2	8	FlexIO 2

9	Power supply unit (PSU) 1	10	I/O module 3
11	PSU 2	12	Drive
13	PSU socket	-	-

 **NOTE**

- I/O modules 1, 2, and 3 can be drive modules or riser modules. The preceding figure is for reference only.
- FlexIO 1 or 2 can be a TM210 NIC, and only one TM280 NIC can be configured. The preceding figure is for reference only.
- FlexIO 1 or 2 is not hot-swappable. If you need to replace it, power off the server.

Table 4-3 Ports on the rear panel

Port	Type	Quantity	Description
VGA port	DB15	1	The VGA port is connected to a terminal, such as a monitor or physical KVM.
USB port	USB 3.0	2	The USB ports allow USB devices to be connected to the server. NOTE Before connecting an external USB device, check that the USB device functions properly. A server may operate abnormally if an abnormal USB device is connected.
Management network port	RJ45	1	This 1000 Mbps Ethernet port is used for server management, and supports 10/100/1000 Mbps auto-negotiation.
Serial port	RJ45	1	The serial port is used as the system serial port by default. You can set it as the iBMC serial port by using the iBMC command. This port is used for debugging.
GE electrical port	RJ45	4/8	Each FlexIO provides four GE electrical ports. A maximum of eight GE electrical ports can be provided through the two FlexIOs.
25GE optical port	SFP28	4	A FlexIO can provide a maximum of four 25GE optical ports. NOTE The 25GE optical ports support rate adaptation to 10GE, and optical modules of different rates are required.

Port	Type	Quantity	Description
PSU socket	-	1/2	Determine the number of PSUs based on actual requirements, but ensure that the rated power of the PSUs is greater than that of the server. You are advised to configure two PSUs to ensure reliable device operating. When one PSU is used, Predicted PSU Status cannot be set to Active/Standby on the iBMC WebUI.

4.2 Indicators and Buttons

Front Panel



- **Figure 4-4** shows the indicators and buttons on the front panel of the server.

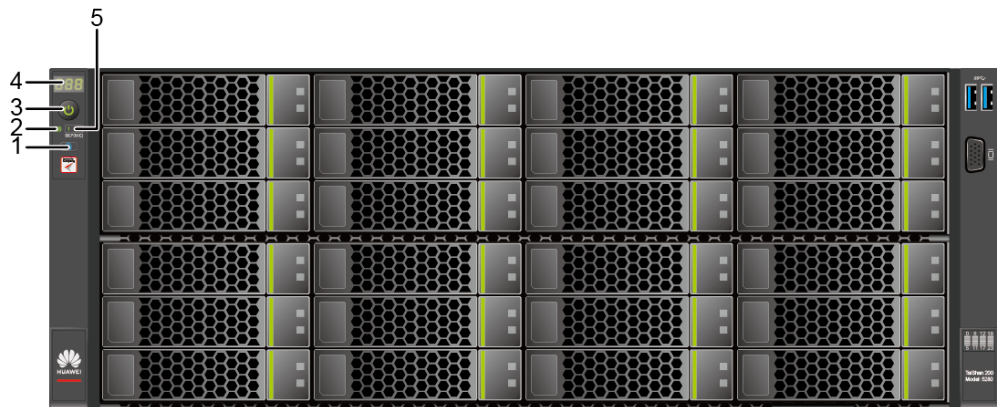

Figure 4-4 Indicators and buttons on the front panel of the server



1	UID button/indicator	2	Health indicator
3	Power button/indicator	4	Fault diagnostic LED
5	FlexIO presence indicators (1 and 2)	-	-

Table 4-4 Indicators and buttons on the front panel

Silkscreen	Indicator/Button	State Description
	Fault diagnostic LED	<ul style="list-style-type: none"> • ---: The server is operating normally. • Error code: A server component is faulty. <p>For details about error code, see the TaiShan Rack Server iBMC Alarm Handling.</p>
	Power button/indicator	<p>Power indicator</p> <ul style="list-style-type: none"> • Steady yellow: The server is in the standby state. • Steady green: The server is properly powered on. • Blinking yellow: The iBMC is starting. • Off: The server is not connected to a power source. <p>Power button</p> <ul style="list-style-type: none"> • When the server is powered on, you can press this button to shut down the OS. • When the server is powered on, you can hold down this button for 6 seconds to force the server to power off. • When the server is in the standby state, you can press this button to start the server.
	UID button/indicator	<p>The UID button/indicator helps identify and locate a device .</p> <p>UID indicator</p> <ul style="list-style-type: none"> • Off: The device is not being located. • Blinking blue (blinking 255 seconds): The device has been located and is differentiated from other devices that have also been located. • Steady blue: The device is being located. <p>UID button</p> <ul style="list-style-type: none"> • You can turn on, turn off, or blink the UID indicator by pressing the UID button on the panel or by using the iBMC CLI or WebUI. • You can press this button to turn on or off the UID indicator. • You can press and hold down this button for about 5 seconds to reset the iBMC.

Silkscreen	Indicator/Button	State Description
	Health indicator	<ul style="list-style-type: none"> Steady green: The server is operating properly. Blinking red at 1 Hz: A major alarm has been generated on the server. Blinking red at 5 Hz: A critical alarm has been generated on the server.
	FlexIO presence indicators (1 and 2)	<ul style="list-style-type: none"> 1 and 2: The numbers 1 and 2 respectively represent FlexIOs 1 and 2. Steady green: The FlexIO card is installed and can be identified. Off: The FlexIO card is not installed or faulty.

Rear Panel

Figure 4-5 shows the indicators on the rear panel of the server.

Figure 4-5 Rear panel indicators

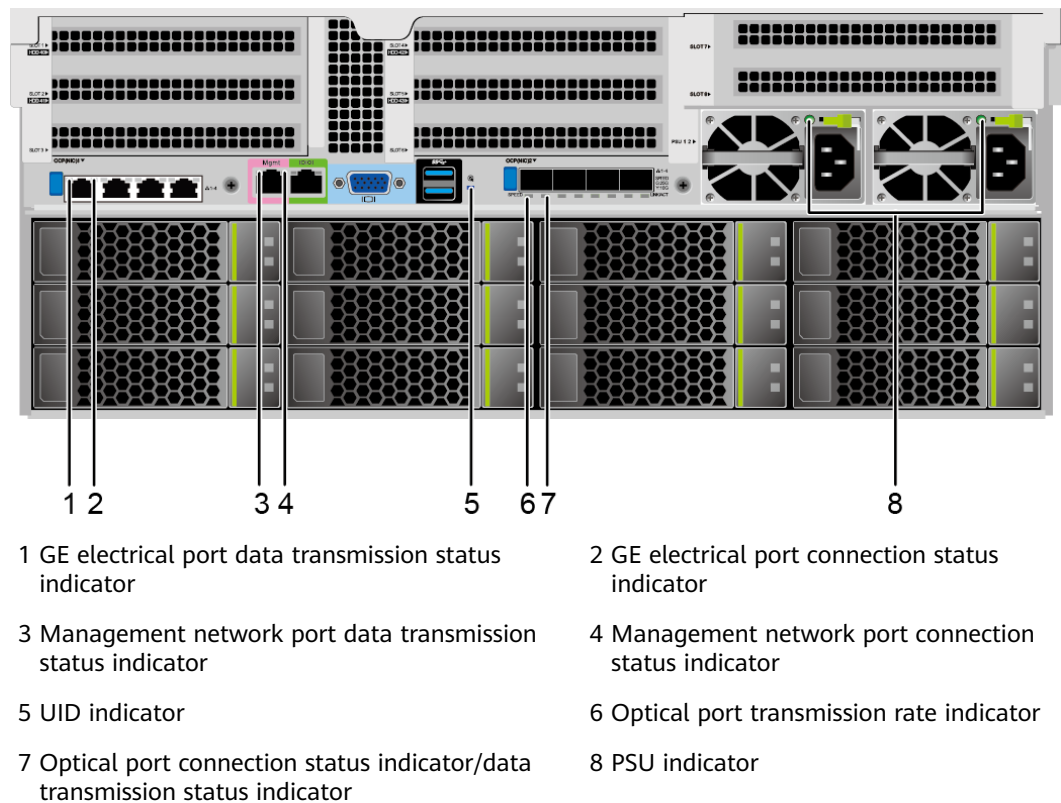

Table 4-5 Indicators on the rear panel

Indicator		State Description
GE electrical port/ Management network port	Data transmission status indicator	<ul style="list-style-type: none"> • Blinking yellow: Data is being transmitted. • Off: No data is being transmitted.
	Connection status indicator	<ul style="list-style-type: none"> • Steady green: The network port is properly connected. • Off: The network port is not connected.
UID indicator		<p>The UID indicator helps identify and locate a device.</p> <ul style="list-style-type: none"> • Off: The device is not being located. • Blinking blue (blinking 255 seconds): The device has been located and is differentiated from other devices that have also been located. • Steady blue: The device is being located. <p>NOTE You can turn on, turn off, or blink the UID indicator by pressing the UID button or remotely running a command on the iBMC CLI.</p>
25 GE optical port	Transmission rate indicator	<ul style="list-style-type: none"> • Steady green: The data transmission rate is 25 Gbit/s. • Steady yellow: The data transmission rate is 10 Gbit/s. • Off: The network port is not connected.
	Connection status indicator/Data transmission status indicator	<ul style="list-style-type: none"> • Steady green: The network port is properly connected. • Blinking green: Data is being transmitted. • Off: The network port is not connected.

Indicator	State Description
PSU indicator	<ul style="list-style-type: none"> ● Steady green: The power input and output are normal. ● Steady orange: The input is normal, but no power output is supplied due to overheat protection, overcurrent protection, short circuit protection, output overvoltage protection, or some component failures. ● Blinking green at 1 Hz: <ul style="list-style-type: none"> – The input is normal, the server is standby. – The input is overvoltage or undervoltage. For details, see TaiShan Rack Server iBMC Alarm Handling. ● Blinking green at 4 Hz: under online PSU firmware upgrade. ● Off: No power is supplied.

SAS/SATA Drive Indicators

Figure 4-6 shows the SAS/SATA drive indicators.

Figure 4-6 SAS/SATA drive indicators

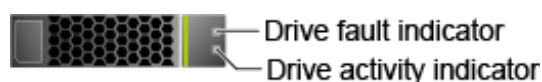

Table 4-6 describes SAS/SATA drive indicators.

Table 4-6 Description of SAS/SATA drive indicators

Drive Activity Indicator (Green Indicator)	Drive Fault Indicator (Yellow Indicator)	Description
Steady on	Off	The drive is in position.
Blinking at 4 Hz	Off	Data is being read or written normally, or data on the primary drive is being rebuilt.
Steady on	Blinking at 1 Hz	The drive is being located by the RAID controller card.
Blinking at 1 Hz	Blinking at 1 Hz	The data on the secondary drive is being rebuilt.

Drive Activity Indicator (Green Indicator)	Drive Fault Indicator (Yellow Indicator)	Description
Off	Steady on	A member drive in the RAID array is removed.
Steady on	Steady on	A member drive in the RAID array is faulty.

NVMe SSD Indicators

Figure 4-7 shows the NVMe SSD indicators.

Figure 4-7 NVMe SSD indicators

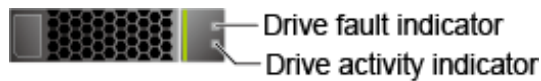

Table 4-7 NVMe SSD indicators

Drive Activity Indicator (Green Indicator)	Drive Fault Indicator (Yellow Indicator)	State Description
Off	Off	The NVMe SSD cannot be detected.
Steady green	Off	The NVMe SSD is detected and working properly.
Blinking green (2 Hz)	Off	Data is being read from or written to the NVMe SSD.
Steady green	Blinking yellow (2 Hz)	The NVMe SSD is being located by the OS or hot-swapped.
Off	Blinking yellow at 0.5 Hz	The NVMe SSD completes the hot removal process and is removable.
Steady green or off	Steady yellow	The NVMe SSD is faulty.

FlexIO

For details about FlexIOs supported by the server, see the [Intelligent Computing Compatibility Checker](#). For details about the specifications and features of each FlexIO card, see the corresponding white paper.

The following figures show the indicators on the FlexIOs.

Figure 4-8 TM210 four GE electrical ports

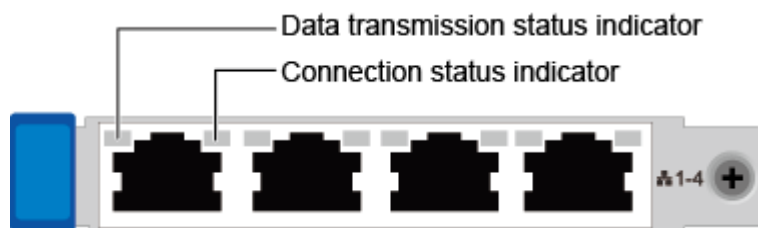

Figure 4-9 TM280 with four 25GE optical ports

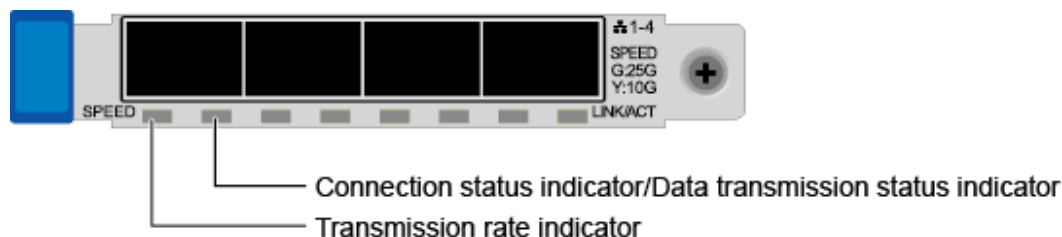

Table 4-8 FlexIO indicators

NIC Type	Indicator	State Description
FlexIO with four GE electrical ports	Data transmission status indicator	<ul style="list-style-type: none"> Blinking yellow: Data is being transmitted. Off: No data is being transmitted.
	Connection status indicator	<ul style="list-style-type: none"> Steady green: The network port is properly connected. Off: The network port is not connected.
FlexIO with four 25GE optical ports	Transmission rate indicator	<ul style="list-style-type: none"> Steady green: The data transmission rate is 25 Gbit/s. Steady yellow: The data transmission rate is 10 Gbit/s. Off: The network port is not connected.
	Connection status indicator/Data transmission status indicator	<ul style="list-style-type: none"> Steady green: The network port is properly connected. Blinking green: Data is being transmitted. Off: The network port is not connected.

4.3 Riser Cards and PCIe Slots

[Figure 4-10](#), [Figure 4-11](#), [Figure 4-12](#) and [Figure 4-13](#) show riser cards supported by I/O modules 1 and 2 in a 5280.

 NOTE

The servers configured with Kunpeng 920 5220 or 3210 processors does not support SAS riser cards.

- The riser card shown in [Figure 4-10](#) can be installed in I/O module 1 or 2. If installed in I/O module 1, the riser card provides PCIe slots 1 to 3. If installed in I/O module 2, the riser card provides PCIe slots 4 to 6.

Figure 4-10 Riser card 1 (three x8 slots)

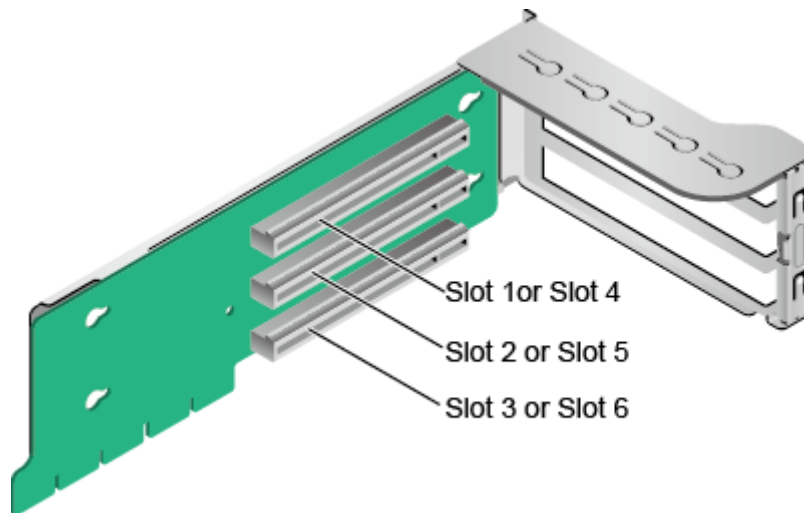

- The riser card shown in http://idplite.huawei.com/idp-edit-war/static/editor/IdpLiteView/DesignLiteView.html?v=V200R002C30B008&projectid=17939338687&number=EN-US_BOOKMAP_0141315219&lan=EN-US&reviewid=&tagname=&mode=&baseline=&startmapnumber=&username=z00404779&errorreport=&displayName=zhangxiaobo%2000404779&commentid=&topicNumber=&isCanEditId=false#fig1963153361417 supports full-height full-length dual-width GPUs. If installed in I/O module 1, the riser card provides PCIe slots 2 and 3. If installed in I/O module 2, the riser card provides PCIe slots 5 and 6.

 NOTE

- When using this card, you must use the power cables delivered with the server.
- Only slots 2 and 5 support full-height full-length dual-width GPUs.

Figure 4-11 Riser card 2 (one x8 slot and one x16 slot)

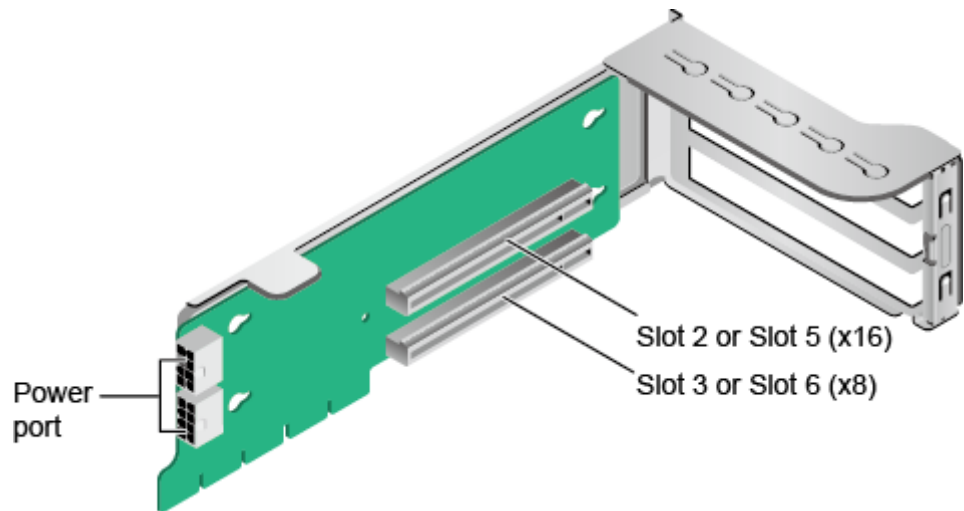

- If I/O modules 1 and 2 are configured with two 2.5-inch rear drives respectively, both I/O modules 1 and 2 support x16 riser cards, as shown in [Figure 4-12](#). This riser card provides slot 3 when installed in I/O module 1, and slot 6 when installed in I/O module 2.

Figure 4-12 Riser card 3 (one x16 slot)

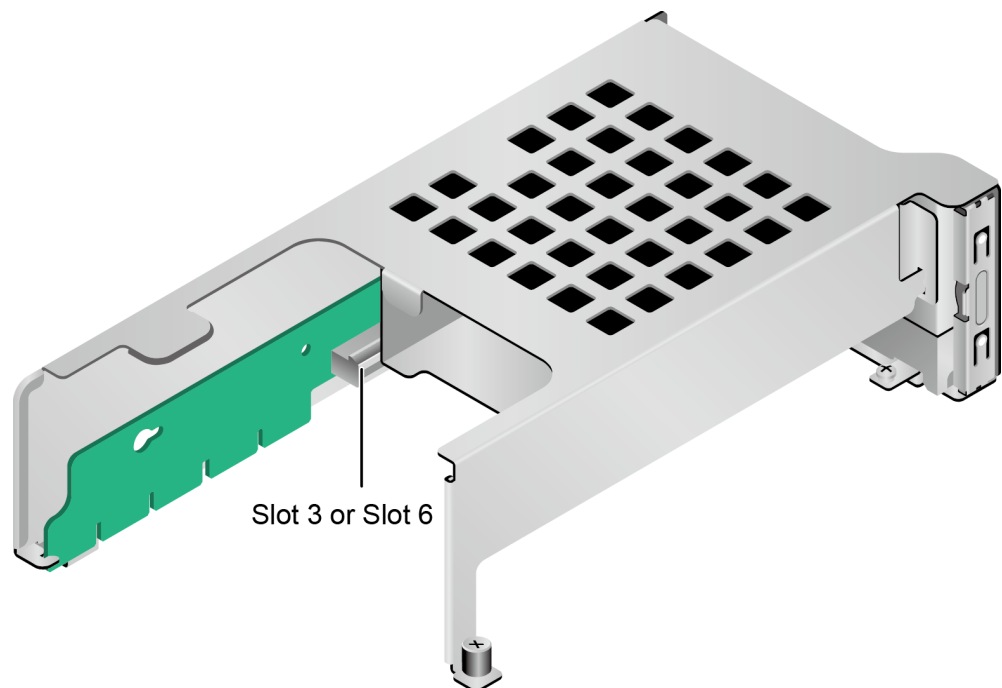

- The SAS riser card shown in [Figure 4-13](#) can be installed in I/O module 1 or 2. By default, it is installed in I/O module 2. When installed in I/O module 1, it occupies PCIe slots 1 to 3 and only slot 3 (x8) is available. When installed in I/O module 2, it occupies PCIe slots 4 to 6 and only slot 6 (x8) is available.

Figure 4-13 Riser card 4 (SAS)

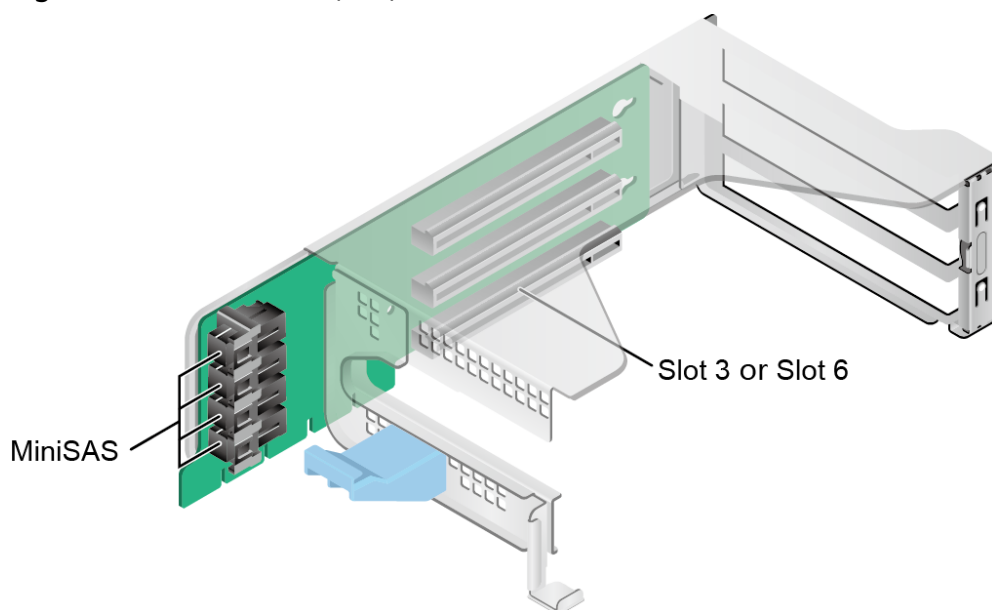
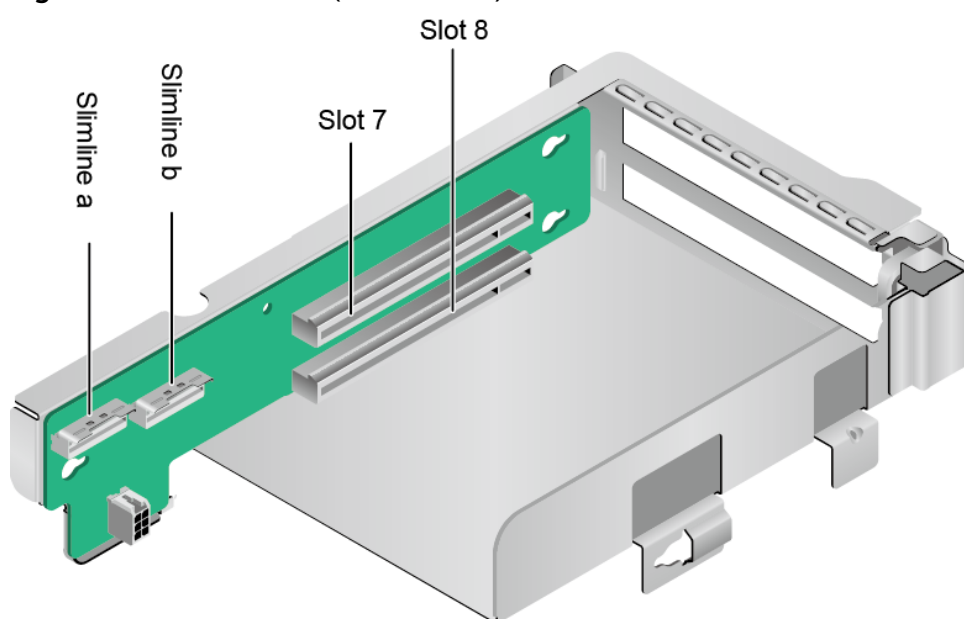

Figure 4-14 and **Figure 4-15** show riser cards supported by I/O module 3.

- If installed in I/O module 3, the riser card shown in **Figure 4-14** provides PCIe slots 7 and 8.

Figure 4-14 Riser card 5 (two x8 slots)



- If installed in I/O module 3, the riser card shown in **Figure 4-15** provides PCIe slot 8.

Figure 4-15 Riser card 6 (one x16 slot)

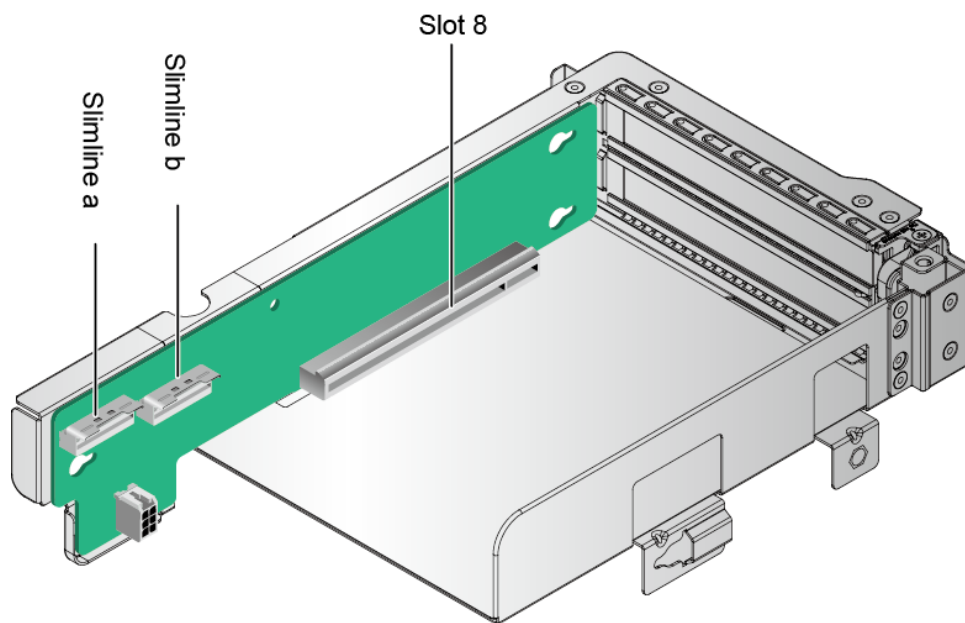
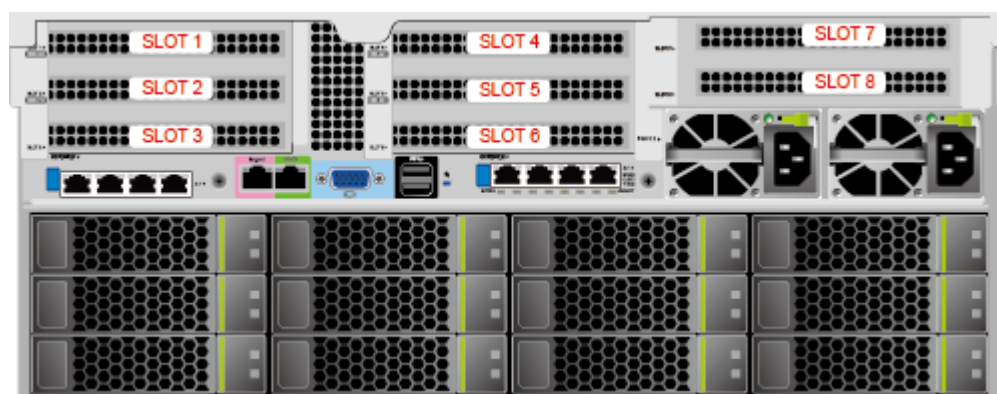

Figure 4-16 shows the rear PCIe slots of the 5280.

Figure 4-16 PCIe slots



I/O module 1 provides slots 1 to 3, I/O module 2 provides slots 4 to 6, and I/O module 3 provides slots 7 and 8.

- If I/O module 1 uses a 2-slot PCIe riser module, slot 1 is unavailable.
- If I/O module 2 uses a 2-slot PCIe riser module, slot 4 is unavailable.
- If I/O module 3 uses a 1-slot PCIe riser module, slot 7 is unavailable.

Table 4-9 describes specifications of the PCIe slots.

Table 4-9 PCIe slot description

PCIe Slot	CPU	PCIe Standards	Connector Width	Bus Width	Port Number in the BIOS	Root Port (B/D/F)	Device (B/D/F)	Slot Size
Slot1	CPU1	PCIe 4.0	x16	<ul style="list-style-type: none"> 2-slot PCIe riser module (PRM): N/A 3-slot PRM: x8 SAS PRM: N/A 	Port0	00/00/0	-	Full-height full-length
Slot2	CPU1	PCIe 4.0	x16	<ul style="list-style-type: none"> 2-slot PRM: x16 3-slot PRM: x8 SAS PRM: N/A 	Port4	00/04/0	-	Full-height full-length
Slot3	CPU1	PCIe 4.0	x16	<ul style="list-style-type: none"> Single-slot PRM: x16 2-slot PRM: x8 3-slot PRM: x8 SAS PRM: x8 	Port12	00/0C/0	-	Full-height half-length
Slot4	CPU2	PCIe 4.0	x16	<ul style="list-style-type: none"> 2-slot PRM: N/A 3-slot PRM: x8 SAS PRM +IOB module: x16 	Port0	80/00/0	-	Full-height full-length

PCIe Slot	CPU	PCIe Standards	Connector Width	Bus Width	Port Number in the BIOS	Root Port (B/D/F)	Device (B/D/F)	Slot Size
Slot5	CPU2	PCIe 4.0	x16	<ul style="list-style-type: none"> • 2-slot PRM: x16 • 3-slot PRM: x8 • SAS PRM +IOB module: N/A 	Port4	80/04/0	-	Full-height full-length
Slot6	CPU2	PCIe 4.0	x16	<ul style="list-style-type: none"> • Single-slot PRM: x16 • 2-slot PRM: x8 • 3-slot PRM: x8 • SAS PRM: x8 	Port16	80/10/0	-	Full-height half-length
Slot7	CPU2	PCIe 4.0	x16	<ul style="list-style-type: none"> • Single-slot PRM: N/A • 2-slot PRM: x8 	Port8	80/08/0	-	Full-height half-length
Slot8	CPU2	PCIe 4.0	x16	<ul style="list-style-type: none"> • Single-slot PRM: x16 • 2-slot PRM: x8 	Port12	80/0C/0	-	Full-height half-length
RAID controller card	CPU1	PCIe 4.0	x8	x8	Port8	00/08/0	-	-

PCIe Slot	CPU	PCIe Standards	Connect or Width	Bus Width	Port Number in the BIOS	Root Port (B/D/F)	Device (B/D/F)	Slot Size
<p>NOTE</p> <ul style="list-style-type: none"> • A PCIe slot that supports a full-height full-length PCIe card is backward compatible with a full-height half-length or half-height half-length PCIe card. A PCIe slot that supports a full-height half-length PCIe card is backward compatible with a half-height half-length PCIe card. • A PCIe slot that supports a PCIe x16 card is backward compatible with a PCIe x8, x4, or x2 card. A PCIe slot that supports a PCIe x8 card is backward compatible with a PCIe x4 or x2 card. • All slots support PCIe cards of up to 75 W. The power of a PCIe card varies depending on its model. For details about supported PCIe cards, use the Intelligent Computing Compatibility Checker. For PCIe cards not listed by the Intelligent Computing Compatibility Checker, contact the local Huawei sales personnel to submit a compatibility test requirement. • When two 2.5-inch drives are installed in I/O module 1 or 2, this module also supports a PCIe x16 riser card in slot 3 or 6. • B/D/F indicates Bus/Device/Function number. • Root Port (B/D/F) indicates the B/D/F of a CPU internal PCIe root port. Device (B/D/F) indicates the B/D/F (displayed on the OS) of an onboard or external PCIe port. • The B/D/F values in this table are default values. The B/D/F values may vary if 1) the server is not fully configured with PCIe cards; 2) the server is fully configured with PCIe cards of different models or in different slots; 3) a PCIe card with a PCI bridge is configured. • A dedicated riser card must be used to support Atlas 300 C accelerator cards. For details, see Intelligent Computing Compatibility Checker. • If a SAS riser card is installed in I/O module 2, an IOB card is required, which provides 16 SAS ports and one PCIe x16 port in slot 4. 								

4.4 Physical Structure

When configured with Kunpeng 920 7260, 5250, 5240, or 5230 processors, the server provides 32 memory slots. [Figure 4-17](#) shows the components of the server.

Figure 4-17 Components of the server powered by Kunpeng 920 7260, 5250, 5240, or 5230 processors

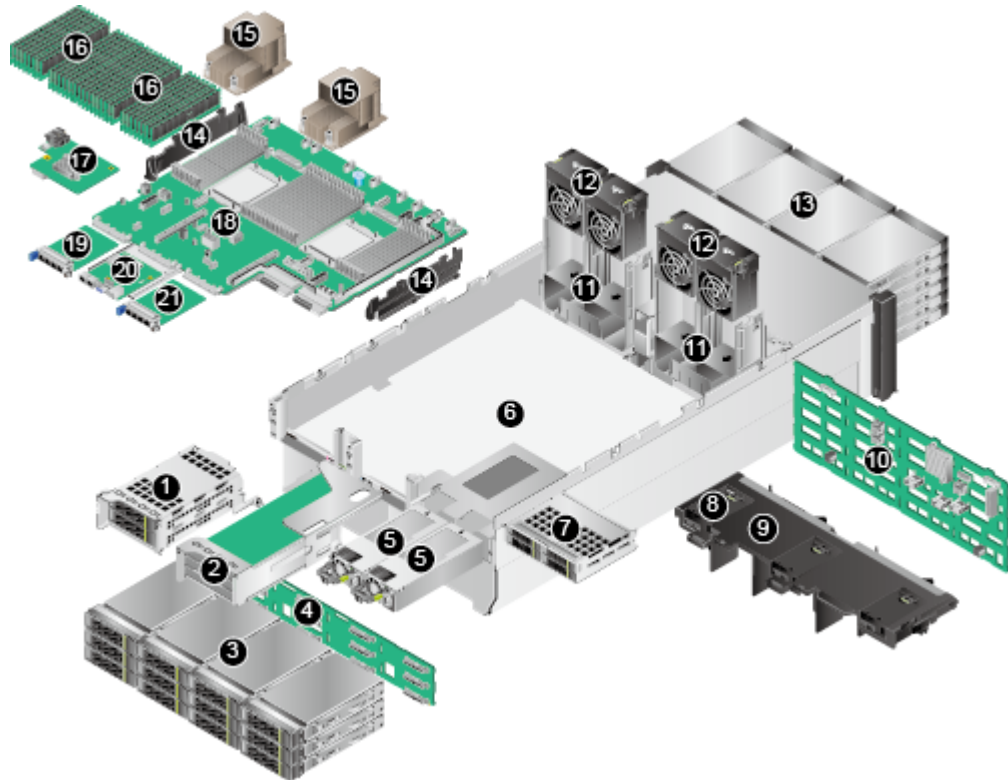

- | | | | |
|----|----------------------|----|-----------------------|
| 1 | I/O module 1 | 2 | I/O module 2 |
| 3 | Rear drives | 4 | Rear-drive backplane |
| 5 | PSUs | 6 | Chassis |
| 7 | I/O module 3 | 8 | Supercapacitor holder |
| 9 | Air duct | 10 | Front-drive backplane |
| 11 | Fan module brackets | 12 | Fan modules |
| 13 | Front drives | 14 | Cable organizers |
| 15 | Heat sinks | 16 | DIMMs |
| 17 | RAID controller card | 18 | Mainboard |
| 19 | FlexIO card 1 | 20 | iBMC card |
| 21 | FlexIO card 2 | - | - |

When configured with Kunpeng 920 5220 or 3210 processors, the server provides 16 memory slots. [Figure 4-18](#) shows the components of the server.

Figure 4-18 Components of the server powered by Kunpeng 920 5220 or 3210 processors

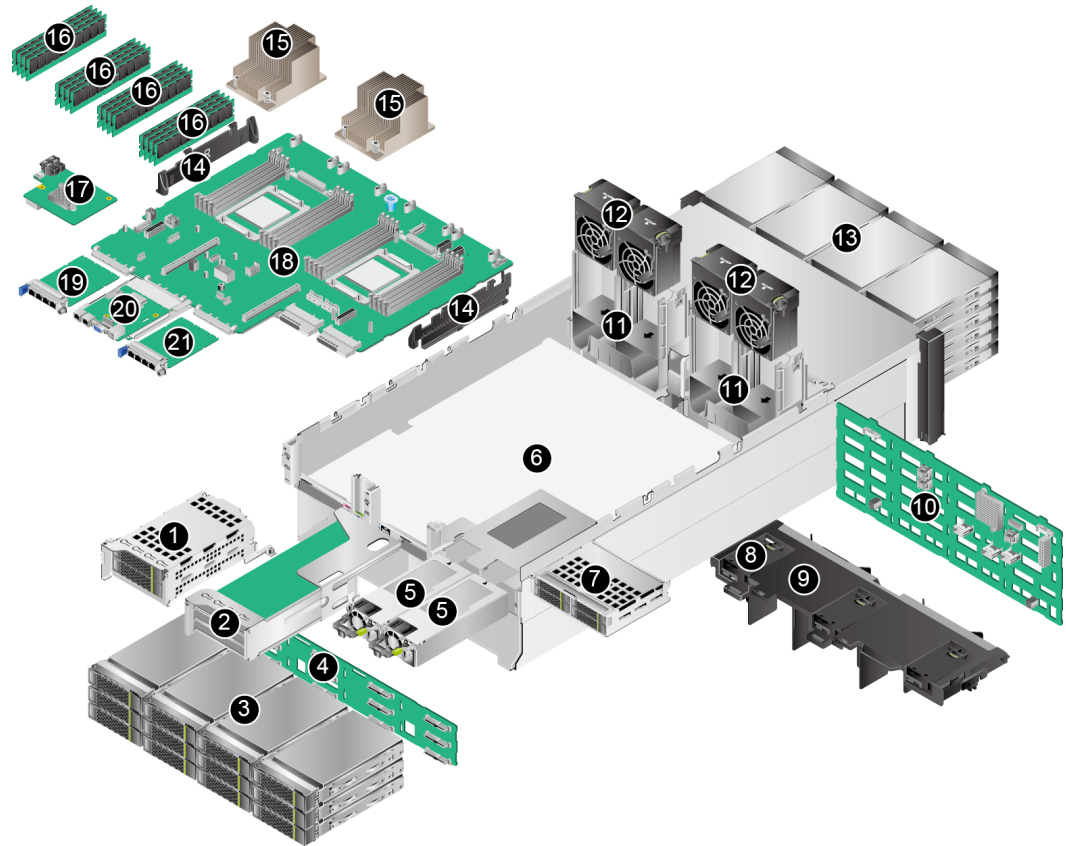

- | | | | |
|----|----------------------|----|-----------------------|
| 1 | I/O module 1 | 2 | I/O module 2 |
| 3 | Rear drives | 4 | Rear-drive backplane |
| 5 | PSUs | 6 | Chassis |
| 7 | I/O module 3 | 8 | Supercapacitor holder |
| 9 | Air duct | 10 | Front-drive backplane |
| 11 | Fan module brackets | 12 | Fan modules |
| 13 | Front drives | 14 | Cable organizers |
| 15 | Heat sinks | 16 | DIMMs |
| 17 | RAID controller card | 18 | Mainboard |
| 19 | FlexIO card 1 | 20 | iBMC card |
| 21 | FlexIO card 2 | - | - |

NOTE

- I/O modules 1, 2, and 3 can be drive modules or riser modules. The preceding figure is for reference only.
- CPUs are integrated on the mainboard and cannot be replaced independently.

5 Product Specifications

[5.1 Technical Specifications](#)

[5.2 Environmental Specifications](#)

[5.3 Physical Specifications](#)

5.1 Technical Specifications

For details about the part numbers and compatibility, use the [Intelligent Computing Compatibility Checker](#).

Table 5-1 Technical specifications

Item	Server Powered by Kunpeng 920 7260, 5250, 5240, or 5230 Processors	Server Powered by Kunpeng 920 5220 or 3210 Processors
Form factor	4U rack server	
Processor	<ul style="list-style-type: none"> • Number of processors: two 64-core, 48-core, 40-core, or 32-core processors with the frequency of 2.6 GHz • L3 cache capacity: up to 64 MB 	<ul style="list-style-type: none"> • Number of processors: two 32-core or 24-core processors with the frequency of 2.6 GHz • L3 cache capacity: up to 32 MB

Item	Server Powered by Kunpeng 920 7260, 5250, 5240, or 5230 Processors	Server Powered by Kunpeng 920 5220 or 3210 Processors
Memory	<ul style="list-style-type: none"> ● Maximum number of slots: 32 DDR4 slots supporting RDIMMs ● Maximum memory speed: 2933 MT/s ● Memory protection functions: ECC, SEC/DED, SDDC, and patrol scrubbing ● Capacity of a single DIMM: 16 GB, 32 GB, 64 GB, or 128 GB <p>NOTE DIMMs of different specifications (such as the capacity, bit width, rank, and height) cannot be installed in one server. That is, all DIMMs on one server must have the same part No.</p>	<ul style="list-style-type: none"> ● Maximum number of slots: 16 DDR4 slots supporting RDIMMs ● Maximum memory speed: 2933 MT/s ● Memory protection functions: ECC, SEC/DED, SDDC, and patrol scrubbing ● Capacity of a single DIMM: 16 GB, 32 GB, 64 GB, or 128 GB <p>NOTE DIMMs of different specifications (such as the capacity, bit width, rank, and height) cannot be installed in one server. That is, all DIMMs on one server must have the same part No.</p>
Storage	<p>Drive:</p> <ul style="list-style-type: none"> ● Support for a variety of drive configurations. For details, see Table 6-5. ● Hot swap of a single drive. <p>RAID controller card:</p> <ul style="list-style-type: none"> ● Support for a variety of RAID controller cards. Use the Intelligent Computing Compatibility Checker to obtain information about the specific RAID controller cards supported. ● Supercapacitor to protect cache data from power failures, and support for RAID level migration, drive roaming, self-diagnosis, and web-based configuration. For details about the RAID controller card, see the RAID Controller Card User Guide (Kunpeng Processors). 	
FlexIO card	<p>Supports a maximum of two FlexIO cards. A FlexIO card can provide either of the following network ports:</p> <ul style="list-style-type: none"> ● Four GE electrical ports, supporting PXE ● Four 25GE/10GE optical ports, supporting PXE <p>NOTE Different optical modules can be used to support 25GE or 10GE optical port rate.</p>	

Item	Server Powered by Kunpeng 920 7260, 5250, 5240, or 5230 Processors	Server Powered by Kunpeng 920 5220 or 3210 Processors
PCIe slot	<ul style="list-style-type: none"> ● A maximum of nine PCIe 4.0 slots: one for a RAID controller card and eight for PCIe cards. The specifications of PCIe 4.0 slots are as follows: I/O modules 1 and 2 provide the following PCIe slots: <ul style="list-style-type: none"> - Two standard full-height full-length PCIe 4.0 x16 slots (width: PCIe 4.0 x8) and one standard full-height half-length PCIe 4.0 x16 slot (width: PCIe 4.0 x8) - One standard full-height full-length PCIe 4.0 x16 slot and one standard full-height half-length PCIe 4.0 x16 slot (width: PCIe 4.0 x8) I/O module 3 provides the following PCIe slots: <ul style="list-style-type: none"> - Two standard half-height half-length PCIe 4.0 x16 slots (width: PCIe 4.0 x8) - One standard half-height half-length PCIe 4.0 x16 slot ● The PCIe expansion slots fully support Huawei proprietary PCIe SSD cards, which bolster I/O performance for applications such as searching, caching, and download services. ● The PCIe slots support Huawei Atlas 300 AI accelerator cards to implement fast and efficient processing and inference, and image identification and processing. <p>NOTE For details about the PCIe card models supported by the 5280, use the Intelligent Computing Compatibility Checker.</p>	
Port	<ul style="list-style-type: none"> ● Front panel: two USB 3.0 ports and one VGA port ● Rear panel: two USB 3.0 ports, one DB15 VGA port, one RJ45 serial port, and one RJ45 management network port 	
Fan module	<p>Four hot-swappable fan modules, providing protection against single-fan failure</p> <p>NOTE Fan modules of the same part No. must be used in a server.</p>	
System management	<p>Huawei iBMC supports Intelligent Platform Management Interface (IPMI), Serial over LAN (SOL), KVM over IP, and virtual media, and provides one 10/100/1000 Mbps RJ45 management network port.</p>	
Security	<ul style="list-style-type: none"> ● Administrator password ● Front bezel (optional) <p>NOTE The front bezel is installed on the front panel and comes with a security lock to prevent unauthorized operations on drives.</p>	

Item	Server Powered by Kunpeng 920 7260, 5250, 5240, or 5230 Processors	Server Powered by Kunpeng 920 5220 or 3210 Processors
Video card	<p>The video card chip SM750 is integrated in the iBMC management chip. It provides 32 MB video memory and supports the maximum display resolution of 1920 x 1080 at 60 Hz with 16 M colors.</p> <p>NOTE</p> <ul style="list-style-type: none"> • Only the maximum resolution supported by the OS built-in driver is supported. • If both the front and rear VGA ports are connected to monitors, only the monitor connected to the front VGA port is available. 	

5.2 Environmental Specifications

Table 5-2 Environmental specifications

Category	Specifications
Temperature	<ul style="list-style-type: none"> • Operating temperature: 5°C to 35°C (41°F to 95°F) (ASHRAE Classes A2 compliant) • Storage temperature (≤ 72 hours): -40°C to +65°C (-40°F to +149°F) • Long-term storage temperature (> 72 hours): 21°C to 27°C (69.8°F to 80.6°F) • Maximum temperature change rate: 20°C/h (36°F/h) <p>NOTE The highest operating temperature varies depending on the configuration. For details, see Table 5-3.</p>
Relative humidity (RH, non-condensing)	<ul style="list-style-type: none"> • Operating humidity: 8% to 90% • Storage humidity (≤ 72 hours): 5% to 95% • Long-term storage humidity (> 72 hours): 30% to 69% • Maximum change rate: 20%/h
Air volume	≥ 204 CFM

Category	Specifications
Maximum altitude	<p>3050 m (10000 ft.)</p> <p>NOTE ASHRAE 2015 compliant:</p> <ul style="list-style-type: none"> • ASHRAE Class A1 and A2 compliant: For altitudes above 900 m (2952.72 ft.), the highest operating temperature decreases by 1°C (1.8°F) for every increase of 300 m (984.24 ft.) in altitude. • ASHRAE Class A3 compliant: For altitudes above 900 m (2952.72 ft.), the highest operating temperature decreases by 1°C (1.8°F) for every increase of 175 m (574.15 ft.) in altitude. • ASHRAE Class A4 compliant: For altitudes above 900 m (2952.72 ft.), the highest operating temperature decreases by 1°C (1.8°F) for every increase of 125 m (410.10 ft.) in altitude.
Corrosive gaseous contaminant	<p>Maximum corrosion product thickness growth rate:</p> <ul style="list-style-type: none"> • Copper corrosion rate test: 300 Å/month (meeting level G1 requirements of the ANSI/ISA-71.04-2013 standard on gaseous corrosion) • Silver corrosion rate test: 200 Å/month
Particle contaminant	<ul style="list-style-type: none"> • The equipment room environment meets the requirements of ISO 14664-1 Class 8. • There is no explosive, conductive, magnetic, or corrosive dust in the equipment room. <p>NOTE It is recommended that the particulate pollutants in the equipment room be monitored by a professional organization.</p>
Acoustic noise	<p>The declared A-weighted sound power levels (LWAd) and declared average bystander position A-weighted sound pressure levels (LpAm) listed are measured at 23°C (73.4°F) in accordance with ISO 7779 (ECMA 74) and declared in accordance with ISO 9296 (ECMA 109).</p> <ul style="list-style-type: none"> • Idle: <ul style="list-style-type: none"> – LWAd: 6.39 Bels – LpAm: 47.8 dBA • Operating: <ul style="list-style-type: none"> – LWAd: 6.68 Bels – LpAm: 52 dBA <p>NOTE Actual sound levels generated during operation vary depending on server configuration, load, and ambient temperature.</p>

Table 5-3 Operating temperature limitations

Model	Max. 30°C (86°F)	Max. 35°C (95°F) (ASHRAE Class A2 Compliant)
EXP model with 36 x 3.5-inch drives	Supports all configurations.	Does not support 64-core CPUs. When the 64-core CPU is used, the mainboard cannot support 35°C (95°F).
Pass-through model with 36 x 3.5-inch drives		
<p>NOTE</p> <ul style="list-style-type: none"> • If one fan fails, the highest operating temperature of the server is 5°C (9°F) lower than that in normal cases. • When powered by Kunpeng 920 5220 or 3210 processors, the server does not support 36 x 3.5-inch pass-through drives. 		

5.3 Physical Specifications

Table 5-4 Physical specifications

Item	Description
Dimensions (H x W x D)	175mm (4U) × 447 mm × 790 mm
Installation space	<p>Requirements for cabinet installation (cabinet compliant with the International Electrotechnical Commission (IEC) 297 standard):</p> <ul style="list-style-type: none"> • Cabinet width: 482.6 mm (19 in.) • Cabinet depth: ≥ 1000 mm (39.37 in.) <p>Requirements for guide rail installation:</p> <ul style="list-style-type: none"> • L-shaped guide rails: apply only to Huawei cabinets. • Adjustable guide rails: apply to a cabinet with a distance of 543.5 mm to 848.5 mm (21.40 in. to 33.41 in.) between the front and rear mounting bars.
Weight in full configuration	<p>Net weight: 65 kg (143.33 lb)</p> <p>Packaging materials: 5 kg (11.03 lb)</p>
Power consumption	<p>The power consumption parameters vary according to configurations (including the ErP standard configuration of the European Union). Use the Intelligent Computing Product Power Calculator to obtain the specific power consumption value.</p>

6 Software and Hardware Compatibility

Use the [Intelligent Computing Compatibility Checker](#) to obtain information about the operating systems and hardware supported by the server.

NOTICE

Do not use incompatible components. Otherwise, the server may fail to work properly. The technical support and warranty do not cover faults caused by incompatible components.

[6.1 CPU](#)

[6.2 Memory](#)

[6.3 Storage](#)

[6.4 I/O Expansion](#)

[6.5 PSU](#)

6.1 CPU

Each Kunpeng 920 processor provides the following features:

- Supports a maximum of 64 cores and 2.6 GHz frequency, allowing flexible configurations of the core quantity and frequency.
- Compatible with the ARMv8-A architecture and supports ARMv8.1 and ARMv8.2 extensions.
- Uses Huawei 64-bit TaiShan cores.
- Integrates a 64 KB L1 instruction cache, a 64 KB L1 data cache, and a 512 KB L2 cache.
- Supports an L3 cache up to 64 MB with a Kunpeng 920 7260, 5250, 5240, or 5230 processor, and an L3 cache of up to 32 MB with a Kunpeng 920 5220 or 3210 processor.
- Superscalar, variable-length, and out-of-order pipelines.
- Supports one-bit error checking and correction (ECC) and two-bit error reporting.

- Uses the high-speed Hydra interface with a channel rate of up to 30 Gbit/s for inter-chip communication.
- Supports up to eight DDR controllers.
- Supports up to eight physical Ethernet ports.
- Supports three 4.0 (16 Gbit/s) controllers, which are also backwards compatible.
- Uses the IMU maintenance engine to collect CPU status information.

6.2 Memory

Memory Capacity Configuration Guidelines

The 5280 supports up to 32 DIMMs. Each Kunpeng 920 7260, 5250, 5240, or 5230 processor supports eight memory channels. Each Kunpeng 920 5220 or 3210 processor supports four memory channels. Each memory channel supports a maximum of two DIMMs.

Table 6-1 RDIMM configuration guidelines of the server with Kunpeng 920 7260, 5250, 5240, or 5230 processors

Item		RDIMM
Number of ranks		Dual rank
Rated speed (MT/s)		2933
Rated voltage (V)		1.2
Operating voltage (V)		1.2
Maximum number of DDR4 DIMMs in a server		32
Maximum capacity per DIMM (GB)		128
Maximum total memory capacity (GB)		4096
Maximum total memory capacity at maximum operating speed (GB)		2048
Maximum operating speed (MT/s)	One DIMM per channel	2933
	Two DIMMs per channel	2666

Table 6-2 RDIMM configuration guidelines of the server with Kunpeng 920 5220 or 3210 processors

Item		RDIMM
Number of ranks		Dual rank
Rated speed (MT/s)		2933
Rated voltage (V)		1.2
Operating voltage (V)		1.2
Maximum number of DDR4 DIMMs in a server		16
Maximum capacity per DIMM (GB)		128
Maximum total memory capacity (GB)		2048
Maximum total memory capacity at maximum operating speed (GB)		1024
Maximum operating speed (MT/s)	One DIMM per channel	2933
	Two DIMMs per channel	2666

Memory Slot Configuration Guidelines (Kunpeng 920 7260, 5250, 5240, or 5230 Processors)

- The 5280 supports a maximum of thirty-two 2933 MHz DDR4 ECC DIMMs. Each processor integrates eight memory channels. RDIMMs are supported.
- The 5280 supports DIMMs of 16 GB, 32 GB, 64 GB, and 128 GB. When the 5280 is fully configured with DIMMs, the maximum memory capacity is 4096 GB.
- Each processor provides 16 DDR4 DIMM slots and integrates eight memory channels. [Table 6-3](#) shows the memory channels.
- [Figure 6-1](#) shows the DIMM installation positions.
- DIMMs of different specifications (such as the capacity, bit width, rank, and height) cannot be installed in one server. That is, a server must use DIMMs of the same part No.
- DIMMs in same memory channel (for example, 000 and 001) must be provided by the same vendor and have the same specifications. DIMMs of different specifications cannot be installed in the same memory channel.
- DIMMs of different types (such as RDIMMs and LRDIMMs) cannot be installed in one server.

Table 6-3 Memory channels (server powered by Kunpeng 920 7260, 5250, 5240, or 5230 processors)

CPU	Channel	DIMM
CPU1	TB_A	DIMM060(G)
		DIMM061(O)
	TB_B	DIMM020(C)
		DIMM021(K)
	TB_C	DIMM040(E)
		DIMM041(M)
	TB_D	DIMM000(A)
		DIMM001(I)
	TA_A	DIMM030(D)
		DIMM031(L)
	TA_B	DIMM070(H)
		DIMM071(P)
	TA_C	DIMM010(B)
		DIMM011(J)
	TA_D	DIMM050(F)
		DIMM051(N)
CPU2	TB_A	DIMM160(G)
		DIMM161(O)
	TB_B	DIMM120(C)
		DIMM121(K)
	TB_C	DIMM140(E)
		DIMM141(M)
	TB_D	DIMM100(A)
		DIMM101(I)
	TA_A	DIMM130(D)
		DIMM131(L)
	TA_B	DIMM170(H)
		DIMM171(P)
TA_C	DIMM110(B)	

CPU	Channel	DIMM
		DIMM111(J)
	TA_D	DIMM150(F)
		DIMM151(N)

Figure 6-1 DIMM installation (server powered by Kunpeng 920 7260, 5250, 5240, or 5230 processors)

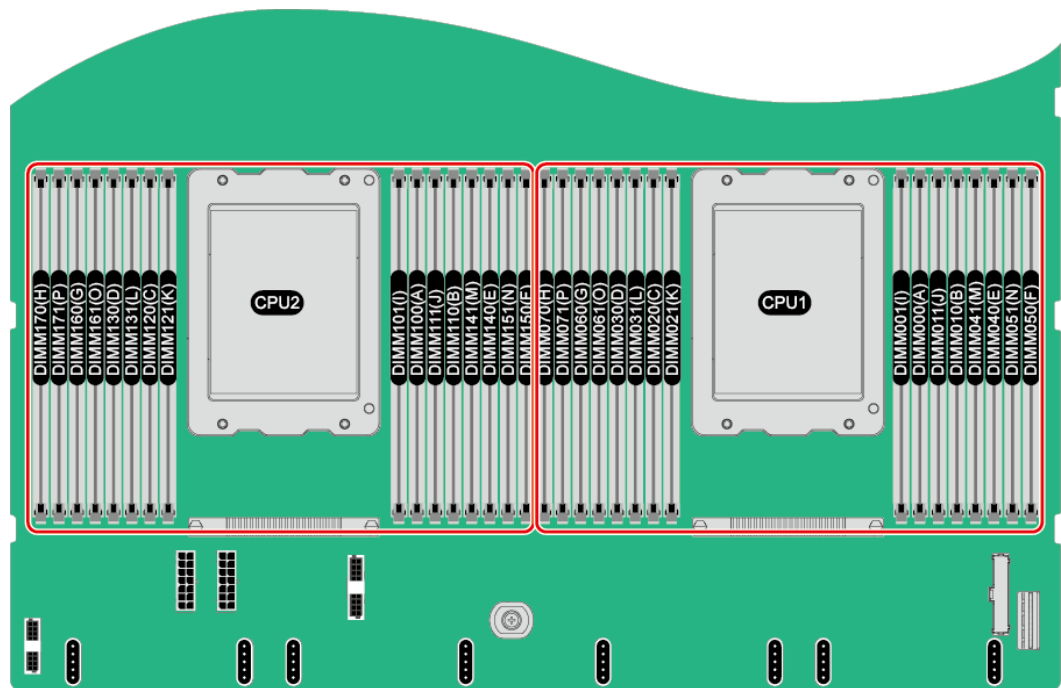

Memory Slot Configuration Guidelines

- The server supports a maximum of sixteen 2933 MHz DDR4 ECC DIMMs. Each processor integrates four memory channels. RDIMMs are supported.
- The server supports DIMMs of 16 GB, 32 GB, 64 GB, and 128 GB. When the server is fully configured with DIMMs, the maximum memory capacity is 2048 GB.
- Each processor provides eight DDR4 DIMM slots and integrates four memory channels. [Table 6-4](#) shows the memory channels.
- [Figure 6-2](#) shows the DIMM installation positions.
- DIMMs of different specifications (such as the capacity, bit width, rank, and height) cannot be installed in one server. That is, a server must use DIMMs of the same part No.
- DIMMs in same memory channel (for example, 000 and 001) must be provided by the same vendor and have the same specifications. DIMMs of different specifications cannot be installed in the same memory channel.
- DIMMs of different types (such as RDIMMs and LRDIMMs) cannot be installed in one server.

Table 6-4 Memory channels (server powered by Kunpeng 920 5220 or 3210 processors)

CPU	Channel	DIMM	
CPU1	TB_A	DIMM030(D)	
		DIMM031(H)	
	TB_B	DIMM020(C)	
		DIMM021(G)	
	TB_C	DIMM011(F)	
		DIMM010(B)	
	TB_D	DIMM001(E)	
		DIMM000(A)	
	CPU2	TB_A	DIMM130(D)
			DIMM131(H)
TB_B		DIMM120(C)	
		DIMM121(G)	
TB_C		DIMM111(F)	
		DIMM110(B)	
TB_D		DIMM101(E)	
		DIMM100(A)	

Figure 6-2 DIMM installation (server powered by Kunpeng 920 5220 or 3210 processors)

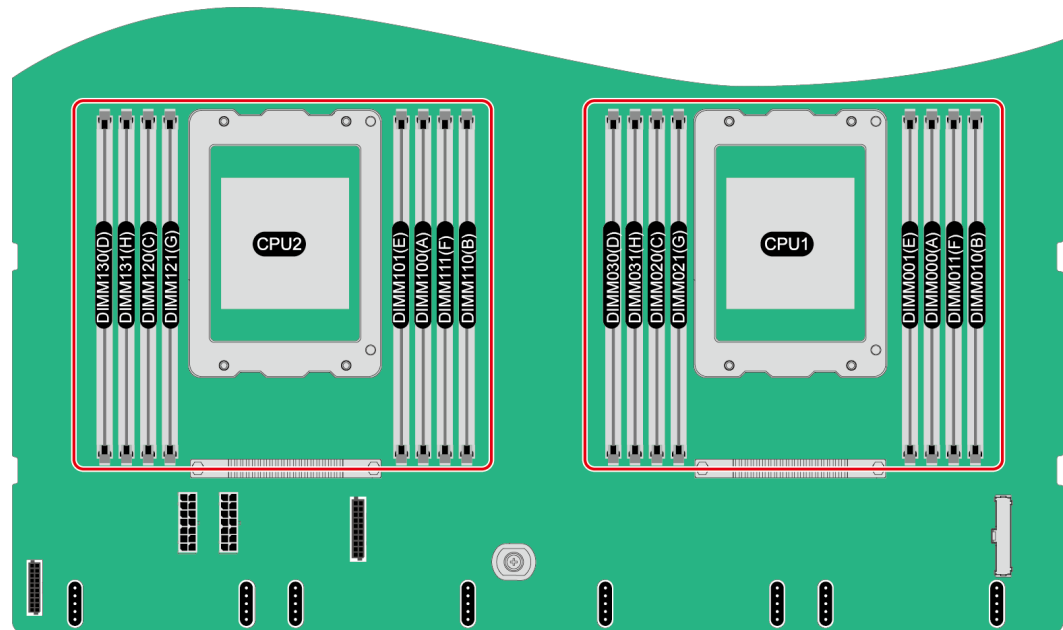

DIMM Installation Guidelines

NOTICE

At least one DIMM must be configured in slots supported by CPU 1.

Optimal memory performance can be achieved if the processors in a server are configured with the same number of DIMMs and the DIMMs are evenly distributed among the memory channels. Unbalanced configuration reduces memory performance and is not recommended.

In unbalanced DIMM configuration, DIMMs are not evenly configured for memory channels or processors.

- If a processor is configured with 3, 5, 7, 9, 10, 11, 12, 13, 14 or 15 DIMMs, the DIMMs are not evenly configured for memory channels.
- If the processors in a server are configured with different number of DIMMs, the DIMMs are not evenly configured for processors.

Memory configuration must comply with the DIMM installation Guidelines. For details, see the [Huawei Server Product Memory Configuration Assistant](#). Install dummy DIMMs in vacant DIMM slots of the server with Kunpeng 920 7260, 5250, 5240, or 5230 processors.

Memory Protection

The server supports the following memory protection technologies:

- ECC

- SEC/DED
- SDDC
- Patrol scrubbing

Supported DIMMs

NOTE

- For details about component options, consult your local Huawei sales representative.
- DIMMs on one server must be of the same model, type (RDIMM or LRDIMM), and specifications (capacity, bit width, number of ranks, and height).

6.3 Storage

The 5280 supports SAS/SATA SSDs and HDDs, and NVMe SSD.

Table 6-5 Drive configurations

Configurati on	Maximum Front Drives	Maximum Rear Drives	Drive Managem ent Mode
Server with 36 x 3.5-inch drives in Expander mode	24 (SAS/SATA drives)	<ul style="list-style-type: none"> • I/O module 1: 2 (SAS/SATA drives) • I/O module 2: 2 (SAS/SATA drives) • I/O module 3: 4 (NVMe SSDs) • Rear drives: 12 (SAS/SATA drives) 	One RAID controller card
Server with 36 x 3.5-inch drives in pass-through mode	24 (SAS/SATA drives)	<ul style="list-style-type: none"> • I/O module 1: 2 (SAS/SATA drives) • I/O module 3: 4 (NVMe SSDs) • Rear drives: 12 (SAS/SATA drives) 	CPU pass-through
[1]: The 5280 configured with the Kunpeng 920 5220 or 3210 processors does not support the 36 x 3.5-inch pass-through drives.			

Table 6-6 provides the comparison between RAID levels in performance, minimum number of drives, and drive usage.

Table 6-6 RAID level comparison

RAID Level	Reliability	Read Performance	Write Performance	Drive Usage
RAID 0	Low	High	High	100%

RAID Level	Reliability	Read Performance	Write Performance	Drive Usage
RAID 1	High	High	Medium	50%
RAID 5	Better than medium	High	Medium	$(N - 1)/N$
RAID 6	Better than medium	High	Medium	$(N - 2)/N$
RAID 10	High	High	Medium	50%
RAID 50	High	High	Better than medium	$(N - M)/N$
RAID 60	High	High	Better than medium	$(N - M * 2)/N$

Note: N indicates the number of member drives in a RAID array, and M indicates the number of spans in a RAID array.

The following figures show the drive slot numbers for these configurations.

Figure 6-3 Server with 36 x 3.5-inch drives in Expander mode



Figure 6-4 Server with 36 x 3.5-inch drives in pass-through mode

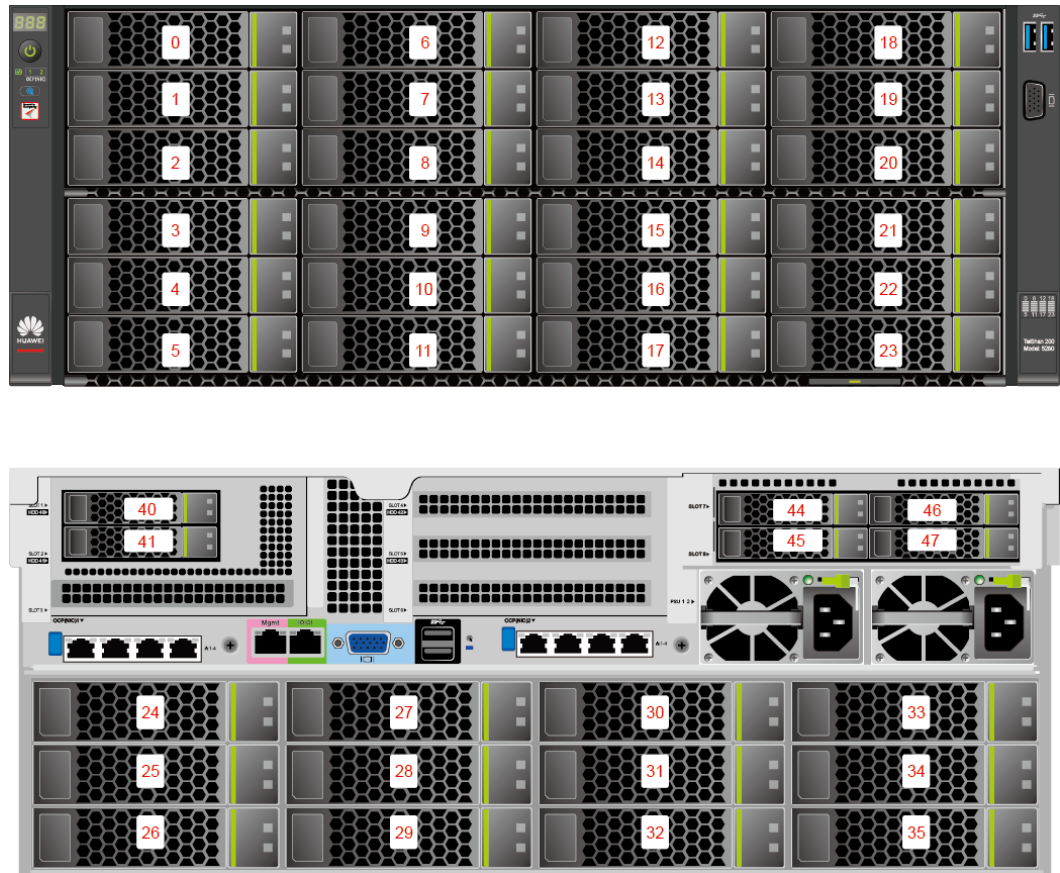

6.4 I/O Expansion

The 5280 supports a wide variety of PCIe cards. You can select the following PCIe cards based on the card type and rate:

- Ethernet card
- Fiber Channel (FC) host bus adapter (HBA)
- InfiniBand (IB) expansion card
- SSD card

NOTE

For details about component options, consult your local Huawei sales representative.

6.5 PSU

[Table 6-7](#) lists the PSUs supported by the 5280.

 **NOTE**

- **Table 6-7** is for reference only. For details about the PSUs available, contact local Huawei sales representatives.
- The recommended current specifications for the external power circuit breaker connected to the server are as follows:
 - AC power supply: 32 A
 - DC power supply: 63 A
- The PSUs are hot-swappable and work in 1+1 redundancy mode.
- A server must use PSUs of the same model.
- The PSUs provide short-circuit protection. The PSUs that support dual input live wires provide double-pole fuse.
- If the input voltage ranges from 200 V to 220 V AC, the output power of the 2000 W AC platinum PSU decreases to 1800 W.

Table 6-7 Supported PSUs

PSU Model	Rated Power	Rated Input voltage
2000 W AC Platinum PSU	The rated power is 2000 W. The power under different input voltages is as follows: <ul style="list-style-type: none"> • 1800 W (input voltage: 200 V AC to 220 V AC) • 2000 W (input voltage: 220 V AC to 240 V AC) • 1800 W (input voltage: 180 V DC to 200 V DC) • 2000 W (input voltage: 200 V DC to 300 V DC) 	AC voltage: 200 V to 240 V HVDC: 180 V to 300 V
1200 W (-48 V) DC PSU	1200W	DC voltage: -48 V DC to -60 V DC
1500 W HVDC PSU	1500W	HVDC: 260 V to 400 V

7 System Management

The 5280 uses Huawei's proprietary intelligent baseboard management controller (iBMC) for remote server management. The iBMC complies with IPMI V2.0 standards and provides reliable hardware monitoring and management.

The iBMC supports the following features and protocols:

- KVM and text console redirection
- Remote virtual media
- IPMI
- Simple Network Management Protocol (SNMP)
- Login using a web browser

Table 7-1 describes the iBMC specifications.

Table 7-1 iBMC specifications

Item	Specifications
Management interface	Integrates with any standard management system through the following interfaces: <ul style="list-style-type: none">• IPMIV2.0• CLI• HTTPS• SNMPv3
Fault detection	Detects faults and accurately locates faults in hardware, for example, a field replaceable unit (FRU).
Alarm management	Supports alarm management and reports alarms using the SNMP trap, Simple Mail Transfer Protocol (SMTP), and syslog service to ensure 24/7 continuous operation.
Integrated virtual KVM	Provides remote maintenance measures for troubleshooting the system, and supports a maximum resolution of 1920 x 1200.

Item	Specifications
Integrated virtual media	Virtualizes local media devices, images, and folders into media devices on a remote server, simplifying OS installation. (The virtual DVD drive supports a maximum transmission rate of 8 MB/s.)
WebUI	Provides a user-friendly graphical user interface (GUI), which simplifies users' configuration and query operations.
Screen snapshots and videos	Allows you to view screen snapshots and videos without login, which facilitates preventive maintenance inspection.
Domain name service (DNS) and directory service	Supports the DNS and directory service, significantly simplifying network and configuration management.
Dual-image backup	Starts software from a backup image if the software fails.
Asset management	Provides intelligent asset management.
IPv6	Supports IPv6 to ensure sufficient IP addresses.

8 Maintenance and Warranty

For details, see [Maintenance & Warranty](#).

9 Certifications

No.	Country/ Region	Certification	Standard
1	China	CCC	GB4943.1-2011 GB9254-2008 (Class A) GB17625.1-2012
2	China	Air Transport of Goods	IATA DGR 60th, 2019

No.	Country/ Region	Certification	Standard
3	Europe	CE	<p>Safety: IEC 60950-1:2005(2nd Edition)+A1:2009 and/or EN 60950-1:2006+A11:2009+A1:2010+ A12:2011</p> <p>EMC: EN 55022:2010 CISPR 22:2008 EN 55024:2010 CISPR 24:2010 ETSI EN 300 386 V1.6.1:2012 ETSI ES 201 468 V1.3.1:2005 IEC 61000-3-2:2005+A1:2008+A2:2009/EN 61000-3-2:2006+A1:2009+A2:2009 IEC 61000-3-3:2008/EN 61000-3-3:2008 IEC 61000-6-2:2005/EN 61000-6-2:2005 IEC 61000-6-4:2006+A1:2010/EN 61000-6-4:2007+A1:2011</p> <p>RoHS: 2002/95/EC, 2011/65/EU, EN 50581: 2012</p> <p>REACH: EC NO. 1907/2006</p> <p>WEEE: 2002/96/EC, 2012/19/EU</p>
4	America	FCC	FCC CFR47 Part 15:2005 Class A
5	Canada	IC	ICES-003:2004 Class A
6	Australia	RCM	EN 55032:2012/AC:2013 EN 55032:2015/AC:2016
7	Japan	VCCI	VCCI V-3:2012
8	-	Commodity inspection	Refer to the product certification certificate.